

PRODUCT SPECIFICATION

Rotating Button LCD MODULE

MODEL:MACHRT-TFT-Φ7821-101 Ver:1.0



< ◇ > Preliminary Specification

< ◆ > Finally Specification

CUSTOMER'S APPROVAL	
CUSTOMER :	
SIGNATURE:	DATE:

APPROVED BY	PM REVIEWED	PD REVIEWED	PREPARED BY

Revision History

Revision	Date	Originator	Detail	Remarks
Ver 1.0	2023.03.25	LQ	Initial Release	

Table of Contents

No.	Item	Page
1.	General Description.....	4
1.1.	Module serial port control function:.....	4
1.2.	Product application:.....	4
2.	Basic Parameters.....	4
3.	Mechanical Characteristics.....	5
3.1.	Appearance picture.....	5
3.2.	Basic Structure.....	5
3.3.	Outline Drawing.....	6
4.	Interface Pins Definition.....	7
5.	Module Parameter.....	7
6.	Optical Characteristics.....	8
7.	Reliability.....	11
8.	Product Packaging Information.....	12

1. General Description

MACHRT-TFT-Φ7821 series module is a module that perfectly combines the display screen, encoder, push button and status LED into a rotating button display. The unique innovative structure and exquisite manufacturing process of the module make it have excellent reliability and excellent control experience. It is applicable to the demand of rotating button control in many industrial applications of electronic products

1.1. Module serial port control function:

1. The module contains MCU. The TFT display is driven and controlled by the MCU and its peripheral device.
2. The module MCU has the communication function with the external HOST MCU according to the specified protocol, and can transmit control commands and display information to each other.
3. The GUI (graphical interface) of the module can be stored in the flash of the module, and can be customized according to the product application.
4. There is special software which can efficiently develop beautiful image and complex control GUI.

1.2. Product application:

1. Smart home appliances: smart refrigerators, household and commercial air conditioners, washing machines, stoves, entertainment electronic devices, and smart home central control modules.
2. Medical beauty products: medical testing instruments, health physiotherapy instruments.
3. Instruments: automobile monitor, motorcycle instrument, building management, security monitoring instrument.
4. Industrial control instruments: electromechanical equipment control display, charging equipment, elevator floor control and display, ordering machine.

2. Basic Parameters

1. 2.1 inch circular display 480*480 TFT/USB Burn + Serial port
2. Annular status LED indicator
3. EC3501 15P3H15 encoder
4. Integral push button
5. FPC standard 0.3mm-10P interface
6. Three point standard screw installation

3. Mechanical Characteristics

3.1. Appearance picture



3.2. Basic Structure

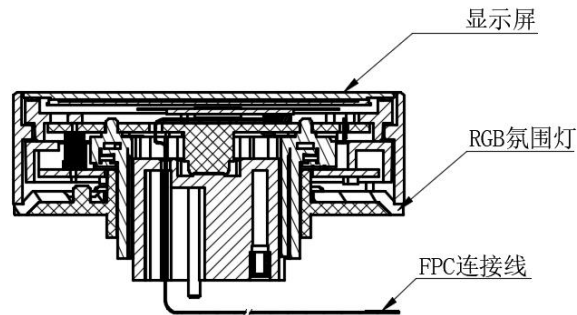

3.3. Outline Drawing

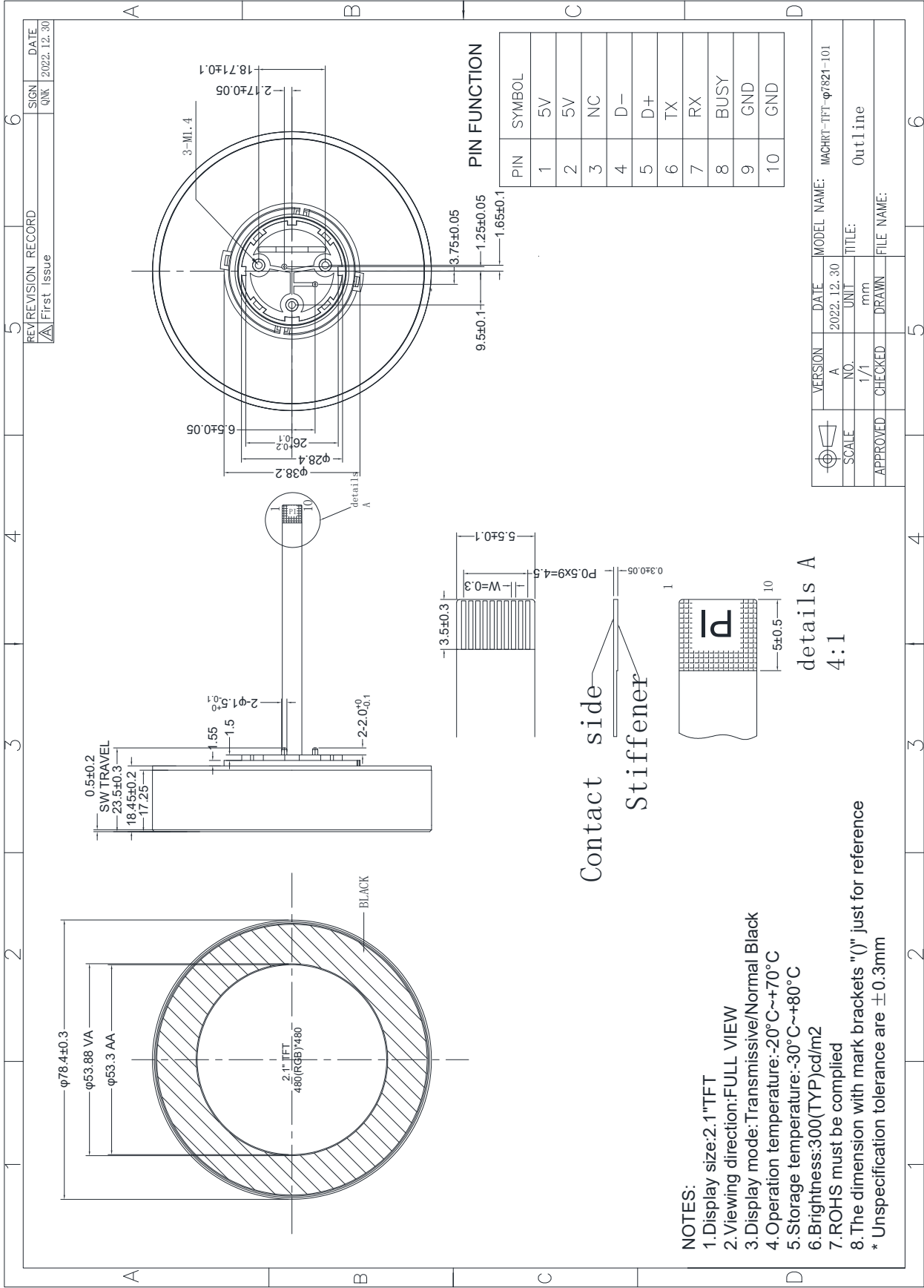

4. Interface Pins Definition

PIN	Symbol	Definition	Remarks
1	5V	Power supply	
2	5V	Power supply	
3	NC	No connection	
4	D-	Data- input pin	
5	D+	Data+ input pin	
6	TX	Serial Send pin	
7	RX	Serial accept pin	
8	BUSY	BUSY Output pin	
9	GND	Power Ground	
10	GND	Power Ground	

5. Module Parameter

Features	Details	Remark
Module Size	Φ78.4(W/H) x 23.5(T) mm	
Viewing Area	Φ53.88 (W/H) mm	
Active Area	Φ53.3 (W/H) mm	
Display Size	2.1"	
View Direction	FULL VIEW	
Display mode	Transmissive / Normal black	
Color	16.7M	
Resolution	480 (W) *480 (H)	
Driver IC	ST7701S	
Luminance	300cd/m ²	
Operating Temperature	-20℃~70℃/96H	
Storage Temperature	-30℃~80℃/96H	
Operating Voltage	4.8V~5.2V, typ: 5V	
Current Consumption	(350)mA	
Weight	TBD	

6. Optical Characteristics

Ta=25°C

Parameter	Symbol	Condition	Min.	Typ.	Max.	Unit	Remark
Contrast Ratio	C/R	$\theta = 0^\circ$	800	1000	-	-	Note(4)
NTSC Ratio	S	$\theta = 0^\circ$	64	69	-	%	Note(7)
Luminance	L	$\theta = 0^\circ$	240	300	-	cd/m ²	Note(5)
Luminance uniformity	UW	$\theta = 0^\circ$	70	80	-	%	Note(3)
Response Time	TR+ TF	25 °C	-	30	35	ms	Note(2)
Color Coordination	R _x	$\theta = 0^\circ$ (Center) Normal viewing angle B/L On	-0.05	(0.628)	+0.05	NTSC (x,y)	Note(6)
	R _y			(0.350)			
	G _x			(0.297)			
	G _y			(0.661)			
	B _x			(0.142)			
	B _y			(0.077)			
	W _x			(0.277)			
	W _y			(0.341)			
Viewing Angle	θ_L	C/R>10	80	85	-	Degree	Note(1)
	θ_R		80	85	-		
	θ_U		80	85	-		
	θ_D		80	85	-		

Test Conditions:

1. VDD=3.3V, IF=20mA (Backlight current), the ambient temperature is+25°C.
2. The test systems refer to Note 8.

Note1: Definition of Viewing Angle: The viewing angle range that the CR>10

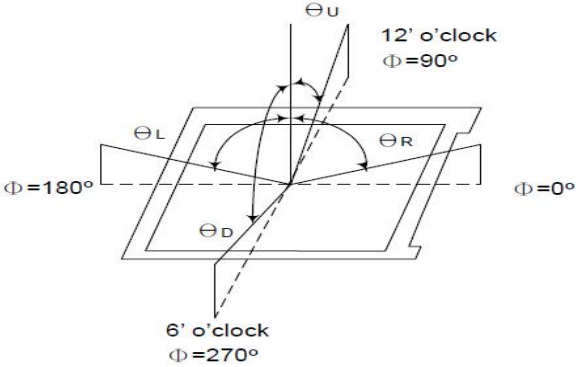

Note2: Definition of Response time: Sum of TR and TF

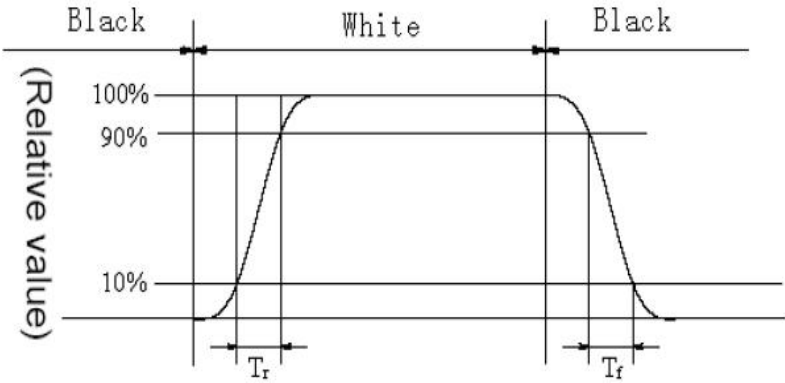

Note 3: Definition of Luminance Uniformity: Active area is divided into 9 measuring areas, every measuring point is placed at the center of each measuring area.

$$\text{Luminance Uniformity} = \frac{\text{Min Luminance of white among 9-points}}{\text{Max Luminance of white among 9-points}} \times 100\%$$

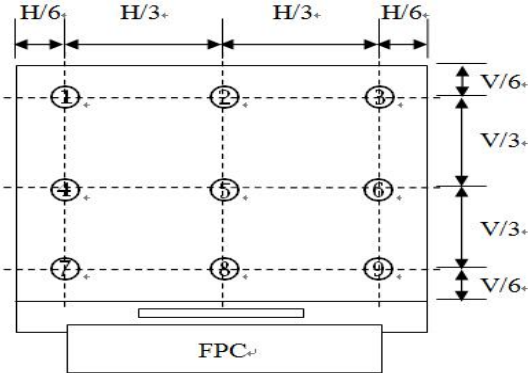

Note4: Definition of Contrast Ratio (CR): measured at the center point of panel

$$\text{Contrast ratio (CR)} = \frac{\text{Luminance measured when LCD on the "White" state}}{\text{Luminance measured when LCD on the "Black" state}}$$

Note 5: Definition of Luminance: Center Luminance of white is defined as luminance values of 1point average across the LCD surface.

Note 6: Definition of Color Chromaticity (CIE 1931)
Color coordinates of white & red, green, blue measured at center point of LCD.

Note 7: Definition of NTSC ratio:

$$\text{NTSC ratio} = \frac{\text{Area of RGB triangle}}{\text{Area of NTSC triangle}}$$

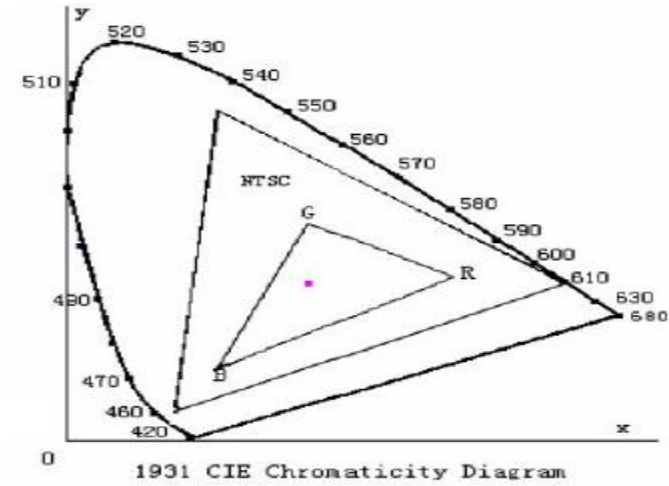

Note 8: Definition of optical measurement system.

The optical characteristics should be measured in dark room. After 5 minutes operation, the optical properties are measured at the center point of the LCD screen. (Response time is measured by Photo detector TOPCON BM-7, Field of view: 1°/Height: 500mm.)

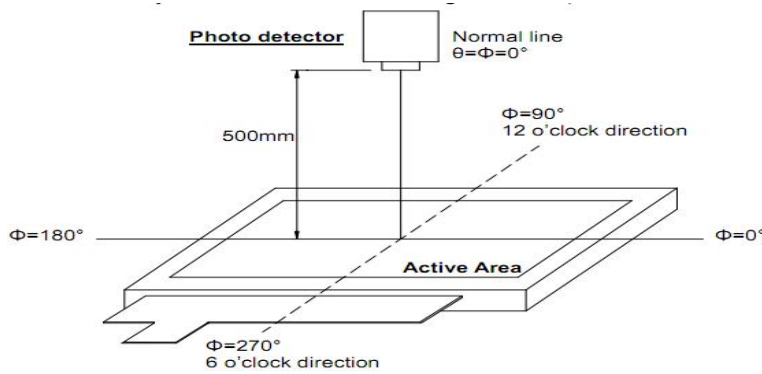

7. Reliability

Item	Test Condition	SPECIFICATIONS
Insulation Impedance	Apply a voltage of 250V DC between the metal outer rotating button and the base for 1 minute.	The resistance between the metal outer rotating button and the base is more than 100M Ω.
Rated Voltage	Apply a voltage of 300V AC between the metal outer rotating button and the base for 1 minute.	No insulation damage
Full Rotation Angle		360° (No stop point)
Rotation Torque		15±7mN.m (150±70gf.cm)
Positioning Points and Positions		30 positioning points (interval angle 12°±2 °)
Axial Compression Strength	At the shaft end, apply a static load force of 5Kgf along the axial direction and press down for 10 seconds (the screw is fixed on the face shell).	The shaft is not damaged and press is normal; The electrical performance is normal
Axial Drawing Strength	At the shaft end, apply a static load force of 5Kgf along the axial direction and pull up for 10 seconds (the screw is fixed on the face shell).	The shaft is not damaged and press is normal; The electrical performance is normal
Rotational Life	Under no-load condition, the shaft rotates 30000 at the speed of 600 ~ 1000 cycles / hour (1 cycle refers to 360° clockwise and 360° counterclockwise)	Torque: - 50% ~ + 10% of the initial value Rotating button display LCD can be powered on and adjusted normally.
High Humidity Experiment	60 ± 3°C, 90 ~ 95%RH, 96 ± 4Hrs Before function test and visual inspection, the product must have enough recovery time, at least 1.5 hours in normal temperature and humidity.	The surface of the outer rotating button is free of cracking and bubbling, and the display screen is free of OCA falling off. Rotating button display LCD can be powered on and adjusted normally.
High Temperature Experiment	70 ± 3°C, 96 ± 4Hrs Before function test and visual inspection, the product must have enough recovery time, at least 1.5 hours in normal temperature and humidity.	The surface of the outer rotating button is free of cracking and bubbling, and the display screen is free of OCA falling off. Rotating button display LCD can be powered on and adjusted normally.

Thermal Cycling Test	阶段 step	温度 Temperature	放置时间 Durationure	The surface of the outer rotating button is free of cracking and bubbling, and the display screen is free of OCA falling off. Rotating button display LCD can be powered on and adjusted normally.
	1	-20℃	0.5 hour	
	2	常温 standard atmospheric conditions	0.5 hour	
	3	70℃	0.5 hour	
	4	常温 standard atmospheric conditions	0.5 hour	
试验周期: 5周 test cycle: 5 cycles				
Before function test and visual inspection, the product must have enough recovery time, at least 1.5 hours in normal temperature and humidity.				
Force of Pressing the Rotating Button	Apply an axial force to the face cover plate until it does not move, and take the large value in the force application process.		250±30gf	
Movement Amount of Pressing the Rotating Button	Fix the product on the face cover plate, apply a static load force of twice the driving force directly above the cover plate, and measure the moving distance when the rotating button is pressed to immobility.		1.3±0.2 mm	
Press Life of the Rotating Button	After the product is fixed, apply a pressing pressure of 250±30gf axially, press it to the end and release it to let it return freely. Press 100000 times. The pressing speed is 1500-1800 times per hour.		The pressing force is - 50% ~ + 10% of the initial value. Rotating button display LCD can be powered on and adjusted normally. The plastic part is free of damage, deformation and rotation is normal.	

8. Product Packaging Information

Storage environment and conditions:

1. It shall be stored in a well ventilated environment with temperature of - 15 °C ~ + 25 °C, relative humidity of 40% - 65% and no harmful gas around.
2. During storage and transportation, the stacking height of products shall not exceed 5 boxes.

Items	Normal Parameters	Limit Parameters	Material Valid Status	Remarks
Temperature	25℃	85℃	Normal	
Humidity	65%	95%	Normal	